

4700 series

profile

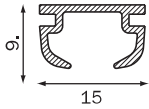

4700

117 gr/m

bending

radius

- R 10 (1012)
- R 10 (1015)
- R >80 (1018)

filler position



profile

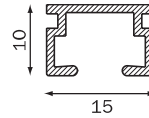

4701

137 gr/m

bending

radius

- R 10 (1012)
- R 10 (1015)
- R >80 (1018)

filler position



Mounting

4700 - series (4702 and 4703 only available on request)

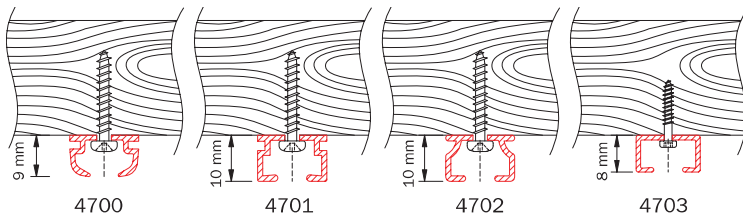

Mounting of punched profiles from the 4700-series with phillips screw 2314 (4700/4701/4702) or Torx screw 2413 (4703)

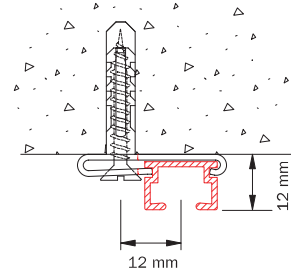

Mounting of the 4700, 4701 or 4702 with ceiling bracket 4750 and a standard wood screw.

Application example

4701

4701 with end cap 4753-12

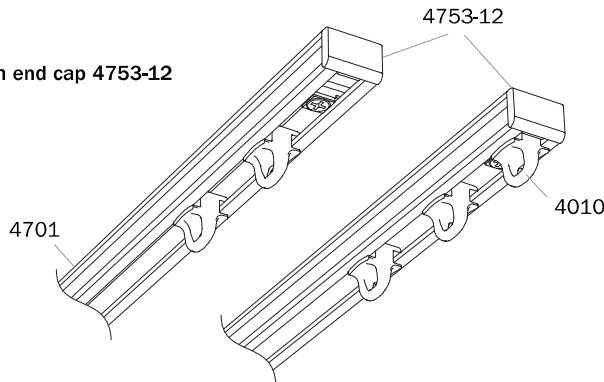

Application of the 4753-12, a product with two functions: only as end cap or as end cap and end stop (applied here to the 4701). An end cap is also available for the more rounded 4700.

Punch types

4700 - series

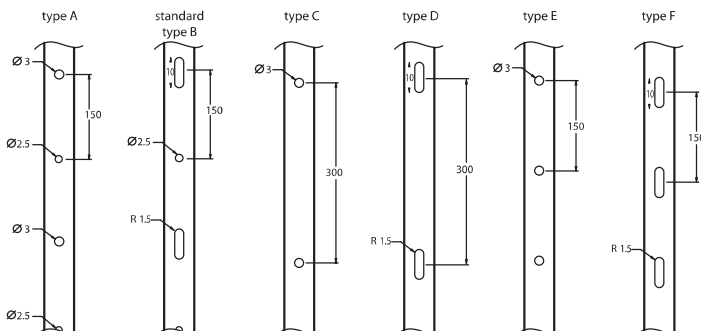

Load table

load table with deflection (mm)

railtype and punch centres (cm)		load (kg)			
		2	4	6	8
4700	15	0.05	0.1	0.15	0.20
	30	0.1	0.2	0.45	0.65
4701	15	0.05	0.15	0.20	0.30
	30	0.1	0.25	0.35	0.45